

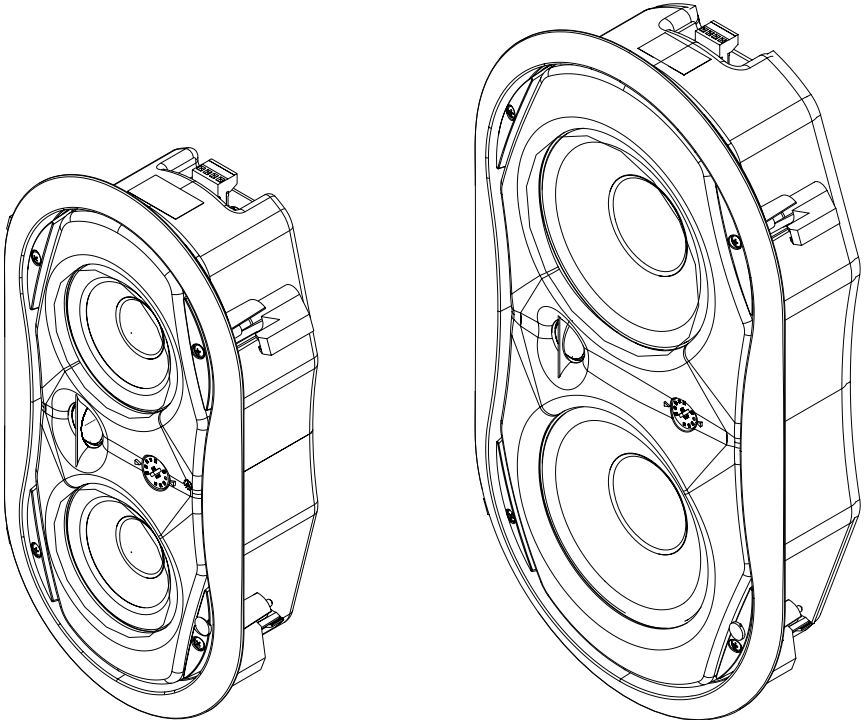

EV Innovative Design



**EVID FM-Series
Loudspeaker User Manual**



Table of Contents

Table of Contents.....	2
Welcome.....	3
Important Features	3
Model Summary	4
Packing List.....	6
Product Feature Identification.....	7
Installation and Wiring	8
Step 1 — Cut the Hole.....	8
Step 2 — Attach Wiring to the Terminal Connector	8
Step 3 — Mount the Speaker into the Wall	10
Step 4 — Adjust Tap Selector.....	10
Step 5 — Insert the Grille	11
Appendix A — Painting the Speaker.....	12
Appendix B — Troubleshooting Table	13
Appendix C — Maintenance.....	14
Appendix D — Product Specifications.....	15

Welcome/Important Features

Welcome

Thank you for purchasing EVID FM Series loudspeakers. Read through this manual to familiarize yourself with features, applications, and precautions before you use these products. EVID FM Series loudspeakers use innovative design and materials to provide premium level performance in a flush-mount format. Two models comprise the EVID FM Series: the FM4.2 with a 4-inch LF driver, a 4-inch LF passive radiator, and a 1-inch, titanium-coated tweeter; the FM6.2 with a 6.5-inch LF driver, 6.5-inch LF passive radiator, and a 1-inch titanium-coated tweeter.

Important Features

- Matches acoustically to the EVID surface mount speaker line
- Model for model, has superior performance to competing brands
- Comes with both 70V/100V or 8 ohm operation standard on every model
- Includes all installation accessories commonly needed for most jobs

Model Summary

EVID FM4.2

The Electro-Voice EVID FM4.2 flush-mounted loudspeaker system is a complete two-way in-wall loudspeaker package. The package consists of a bezel assembly, grille, rear enclosure, 4 inch two-way loudspeaker coupled with a 4 inch passive radiator and an internal line-matching transformer. The loudspeaker features 4 inch low-frequency cone and high-temperature voice-coil assembly along with a 4 inch long excursion passive radiator and titanium coated dome tweeter. The EVID FM4.2 loudspeaker utilizes a crossover network, centered at 3,600 Hz, that provides 16-dB-per-octave tweeter protection outside of its operating range. In addition the EVID FM4.2 features a comprehensive protection circuit to shield the woofer and tweeter drivers from excessive power levels.

The EVID FM4.2 utilizes a transformer that offers a selection of 1.75, 3.75, 7.5, 15 or 30 watts delivered to the loudspeaker system using either 70-V or 100-V lines. The wattage is selected via a convenient switch on the front baffle. The unit can also be operated as an 8 ohm speaker via the same front panel selector switch.

The perforated grille is finished in semi-gloss white powder-coated enamel. The baffle and bezel is constructed from heat resistant ABS. The rear enclosure is constructed from zinc-plated, steel. The rear enclosure provides an optimum internal volume, ensuring extended low-frequency performance. It is constructed from heavy-gauge, rugged steel. The steel rear enclosure was optimized using FEA to virtually eliminate panel resonance. The entire enclosure is less than 4 inch deep providing an easy installation into nearly any tight wall or ceiling space. A rear cover, with provisions for a junction box fitting, provides access to a 4-pin terminal block that allows direct connection to the speaker and provides pass through to additional speakers. FM4.2 loudspeakers provide wide dispersion, high-efficiency, high-maximum output, ease of installation, and wide-range reproduction of music or voice.

Model Summary

EVID FM6.2

The Electro-Voice EVID FM6.2 loudspeaker system is a complete two-way in-wall loudspeaker package. The package consists of a bezel assembly, grille, rear enclosure, 6.5 inch two-way loudspeaker coupled with a 6.5 inch passive radiator and an internal line-matching transformer. The loudspeaker features 6.5 inch low-frequency cone and high-temperature voice-coil assembly along with a 6.5 inch long excursion passive radiator and titanium coated dome tweeter. The EVID FM6.2 loudspeaker utilizes a crossover network, centered at 3,300 Hz, that provides 16-dB-per-octave tweeter protection outside of its operating range. In addition the FM6.2 features a comprehensive protection circuit to shield the woofer and tweeter drivers from excessive power levels.

The FM6.2 utilizes a transformer that offers a selection of 7.5, 15, 30, or 60 watts delivered to the loudspeaker system using either 70-V or 100-V lines. The wattage is selected via a convenient switch on the front baffle. The unit can also be operated as an 8 ohm speaker via the same front panel selector switch.

The perforated grille is finished in semi-gloss white powder-coated enamel. The baffle and bezel is constructed from heat resistant ABS. The rear enclosure is constructed from zinc-plated, steel. The rear enclosure provides an optimum internal volume, ensuring extended low-frequency performance. It is constructed from heavy-gauge, rugged steel. The steel rear enclosure was optimized using FEA to virtually eliminate panel resonance. The entire enclosure is less than 4 inch deep providing an easy installation into nearly any tight wall or ceiling space. A rear cover, with provisions for a junction box fitting, provides access to a 4-pin terminal block that allows direct connection to the speaker and provides pass through to additional speakers. FM6.2 loudspeakers provide wide dispersion, high-efficiency, high-maximum output, ease of installation, and wide-range reproduction of music or voice.

Packing List

EVID FM Series Packing List		
Figure	Quantity	Part
A	2	Ceiling Speakers
B	2	Grilles
C	1	User Manual
D	1	Warranty Card
E	1	Datasheet
F	2	Paint Shields

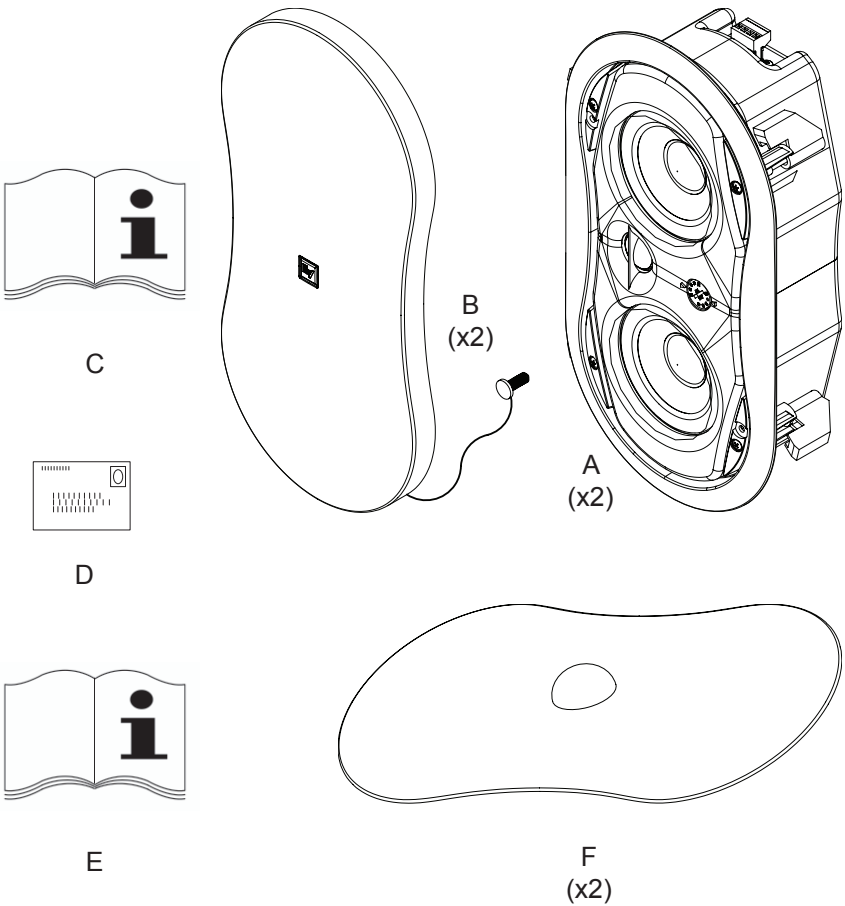

Figure 1:
Packing List

Product Feature Identification

EVID FM Series Systems (Sold in Pairs)		
Model	Part No.	Description
FM4.2	FM4.2	Dual 4 inch Flush-Mounted Two-Way Loudspeaker
FM6.2	FM6.2	Dual 6.5 inch Flush-Mounted Two-Way Loudspeaker

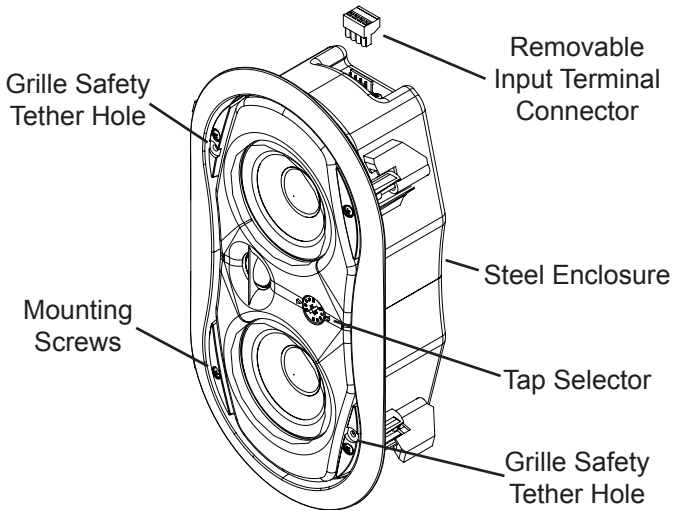

Figure 2:
Front of Speaker

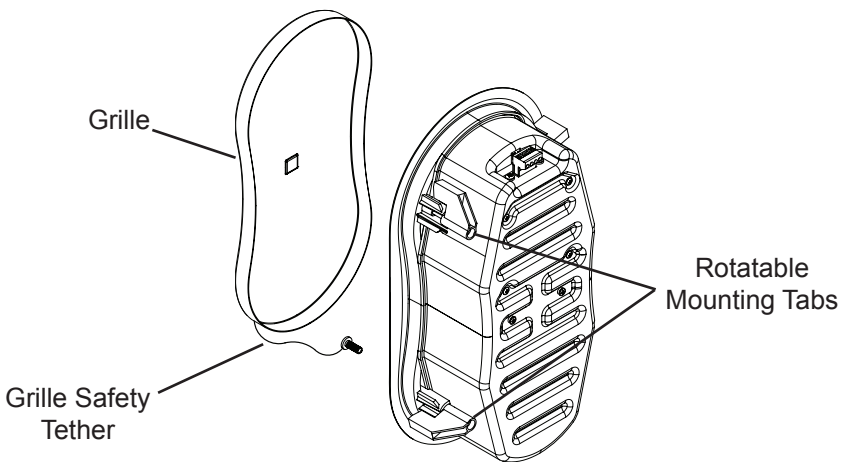

Figure 3:
Rear of Speaker

Installation and Wiring

INSTALLATION NOTE: CONTROLLING VIBRATION

Because of their high performance, EVID FM Series loudspeakers can generate substantial vibration, which can cause buzzing in loose sections of the wall, depending on the character of the wall and related components.

Step 1: Cut the Hole

For sheetrock walls, cut out the hole by tracing the cardboard template (See Figure 4). If the wire has been pre-installed, pull the wiring through the cutout hole.

Step 2: Attach Wiring to the Terminal Connector

Insert the bare end of wire into the appropriate connector terminals as described below and screw down the hold-down screw until tight, using a small screwdriver.

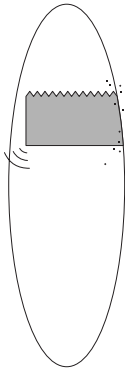

Figure 4:
Cutting Hole

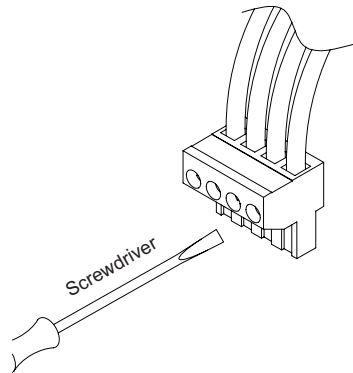

Figure 5:
Tighten with Screwdriver

INSTALLATION NOTE: CONNECTOR WIRING GUIDELINES

The input connector's 4 terminals are numbered and marked on the connector. Pins 1 and 2 are positive (+); pins 3 and 4 are negative (-). (Pin 1 is connected to Pin 2 and Pin 3 is connected to Pin 4 inside the speaker.) Pins 1 and 4 are used as daisy-chain connections to other loudspeakers.

Installation and Wiring

INSTALLATION NOTE: CONNECTOR WIRING GUIDELINES

Two possible layouts for wiring a group of speakers are described below.

1. Wiring in parallel. Connect the wire pair of the subsequent speaker to pins 2 and 3. When one input connector is removed, subsequent speakers will remain connected. See Figure 6.
2. Daisy-chaining. Connect the wire pair of the subsequent speaker to pins 1 and 4. When one input connector is removed, subsequent speakers will also be disconnected. See Figure 7.

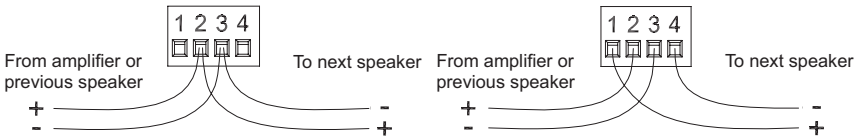

Figure 6:
Parallel Wiring

Figure 7:
Daisy-Chain Wiring

When all wiring has been completed to the connector, plug the connector into the socket in the speaker's terminal cup. See Figure 8. Tighten all screws to eliminate vibration.

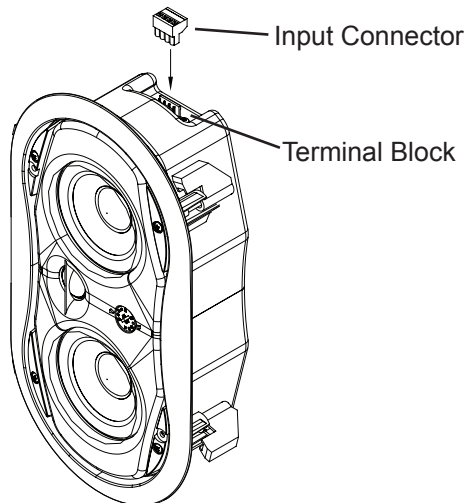

Figure 8:
Plug Connector Into Socket

Installation and Wiring

Step 3: Mount the Speaker Into the Wall

Push the speaker into the hole until the front baffle rim is flush with the wall. Tighten the mounting tabs by turning the screw clockwise until the speaker is secure. Please note that the first clockwise quarterturn rotates the attachment tabs outward. The remaining turns tighten the tabs down onto the back of the wall (see Figure 10).

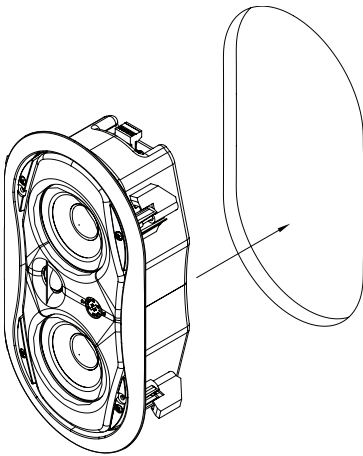

Figure 9:
Mount Speaker Into Wall

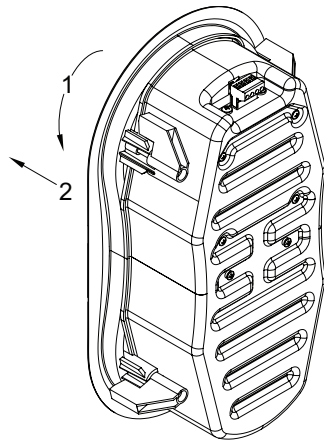

Figure 10:
Tighten Mounting Tabs

INSTALLATION NOTE: MOUNTING TABS

For each attachment screw, first turn one halfturn counterclockwise to release the mounting tab from its guide.

Step 4: Adjust Tap Selector

The tap selector switch is located on the front baffle. Adjust the speaker to the appropriate tap setting before installing the grille. In some 70V/100V constant voltage installations it is advisable to leave the grilles off if final speaker audio level balance adjustments are to be made later. After the levels are adjusted the grilles can then be installed.

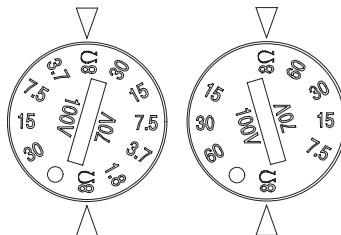

Figure 11:
Adjust Tap Selector (Left: FM4.2, Right: FM6.2)

Installation and Wiring

EVID FM4.2

In addition to the 8 ohm setting, the power taps are 30 W, 15 W, 7.5 W, and 3.75 W at both 70.7V and 100V, with a 1.75 W tap for 70.7V only.

EVID FM6.2

In addition to the 8 ohm setting, the power taps are 60 W, 30 W, and 15 W at both 70.7V and 100V, with a 7.5 W tap for 70.7V only.

Step 5: Attach the Grille

INSTALLATION NOTE: GRILLE SAFETY FEATURE

EVID grilles features a unique safety tether to prevent the grille from falling if the grille is removed or comes loose after installation. First, install the grille's safety tether by pushing the grille fastener into the hole in the front of the baffle (see Figure 12). Second, press the grille into place until the front of the grille is flush with the rim of the baffle. Make sure the grille is securely seated to prevent it from vibrating loose. If you need to remove the grille, the easiest way is to insert two bent paper clips or other pointed objects into holes in the grille, then apply slow even pressure to pull down on the grille until that section of the grille comes out slightly. Continue the same procedure around the perimeter of the grille, loosening a portion at a time until the grille is removed.

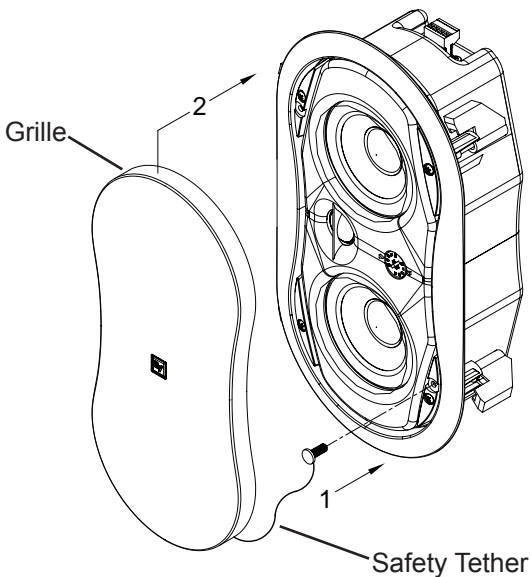

Figure 12:
Attach the Grille

Appendix A - Painting the Speaker

If the speaker is installed in an area where the interior design requires a color match, these speakers are simple to paint. The speakers can accommodate almost any type of latex or oil-based paint. The bezel/rim can be painted before installation or after mounting into the wall.

Painting Process

Clean the rim and grille with mineral spirits or other light solvent. Do not use harsh solvents such as gasoline, kerosene, acetone, or other chemicals. If you use these cleaners you may permanently damage the enclosure. Also, don't use abrasives products such as sandpaper or steel wool. Either by rolling or spraying, apply two or more thin coats of paint. If you are spraying, hold the spray can at the angles shown in Figure 13. If you are painting the grille also, you must first remove the internal grille cloth. Spray painting is strongly recommended. If the grille is rolled or brush painted, the grille may become clogged with paint and the sound quality will suffer. After the paint has dried, replace the internal grille cloth. If you wish to paint the speaker along with the wall after installation, insert a plastic or cardboard paint shield into the front of the speaker to mask the drivers and internal baffle, paint the speaker, then remove the shield.

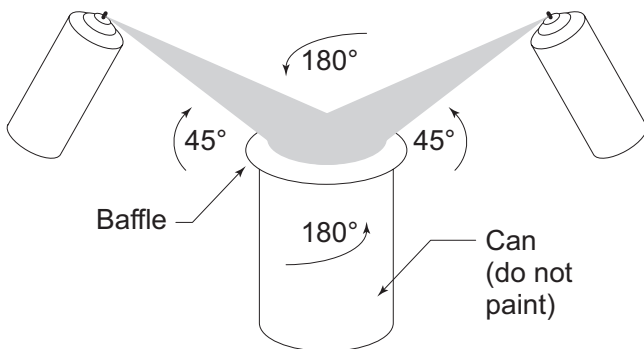

Figure 13:
Spray-Painting Angles
EVID FM Series Installation and Operation Manual

Appendix B - Troubleshooting Table

Problem	Possible Causes	Action
No Output	Amplifier	Make sure the amplifier channel is being fed an input signal (preferably via a “signal input” indicator on the amp).
		Check that the amplifier channel’s volume is turned up.
		Connect the speaker and cable, which had no output to another amplifier channel, making sure an input signal is fed to the new amp channel. If you then get output, the problem was the amplifier channel. If not, then the problem may be in the cable or speaker.
	Speaker Cable(s)	Replace the cable(s) connecting the loud-speaker system and amplifier.
Questionable or Intermittent Output such as Crackling	Faulty Connection	Check all cabling for proper connector contact. A bad connection can result in intermittent contact or dramatically increased resistance, which in turn can cause reduced output or noises unrelated to the signal.
	Improper Power Tap Setting	Check the power tap setting under the speaker grille to ensure the setting is appropriate for the installation and amplifier chosen.
Constant Noise such as Buzzing, Hissing, or Humming	A Faulty Electronic Device in the Signal Chain	Since loudspeakers cannot generate these sounds by themselves, you may have a faulty electronic device in the signal chain.
	Poor System Grounding	Check and correct the system grounding, as required.
Poor Low-Frequency Output	Out-of-Polarity Hookup Between Multiple Speakers	When two speakers are hooked up out of polarity (out of phase), the low frequencies cancel each other out. Try reversing the polarity of one of the speakers either by turning around a dual-banana plug at the amplifier or by reversing the tip/sleeve leads on the jack. Whichever condition results in greater low-frequency output is the in-polarity condition.
If none of the suggestions above solves your problem, contact your nearest EV service center or EV distributor.		

Appendix C - Maintenance

No maintenance is required when installed in accordance with installation and wiring guidelines described in this manual.

Appendix D - Specifications

EVID FM4.2

EVID FM6.2

Freq. Response (-3 dB):	70 Hz - 20 kHz	Freq. Response (-3 dB):	60 Hz - 20 kHz
Freq. Range (-10 dB):	52 Hz - 20 kHz	Freq. Range (-10 dB):	52 Hz - 20 kHz
Axial Sensitivity:	87 dB (SPL 1W/1m)	Axial Sensitivity:	90 dB (SPL 1W/1m)
Impedance:	8 ohms nominal (transformer bypass)	Impedance:	8 ohms nominal (transformer bypass)
Crossover Frequency:	3.6 kHz	Crossover Frequency:	3.3 kHz
Rec. Highpass Frequency:	70 Hz	Rec. Highpass Frequency:	60 Hz
HF Transducer:	1 in. (25.4 mm)	HF Transducer:	1 in. (25.4 mm)
LF Transducer: Passive Radiator:	4 in. (101.6 mm) 4 in. (101.6 mm)	LF Transducer: Passive Radiator:	6.5 in. (165.1 mm) 6.5 in. (165.1 mm)
Transformer Taps:	70V: 1.75, 3.75, 7.5, 15, or 30W 100V: 3.75, 7.5, 15, or 30W Bypass: 8 ohms nominal	Transformer Taps:	70V: 7.5, 15, 30, or 60W 100V: 15, 30, or 60W Bypass: 8 ohms nominal
Connectors:	4 pin phoenix style terminals	Connectors:	4 pin phoenix style terminals
Enclosure Material:	Baffle: UL 94V-O rated ABS Backcan: Zinc plated steel	Enclosure Material:	Baffle: UL 94V-O rated ABS Backcan: Zinc plated steel
Grille:	Perforated powder- coated steel with safety tether	Grille:	Perforated powder- coated steel with safety tether
Mounting System:	Integrated toggle anchors	Mounting System:	Integrated toggle anchors
Support Hardware:	Cutout template, Paint Shield	Support Hardware:	Cutout template, Paint shield
Dimensions:	349.9mm x 188.3mm x 96.5mm (13.77" x 7.42" x 3.80")	Dimensions:	465.4mm x 256.4mm x 100.3mm (18.32" x 10.09" x 3.95")
Net Weight (Each):	2.9 kg (6.5 lb)	Net Weight (Each):	5.8 kg (12.7 lb)
Shipping Weight (Pair):	6.8 kg (15.0 lb)	Shipping Weight (Pair):	12.9 kg (28.4 lb)

All Specifications based on Half-Space Environment as flush-mounted.

Germany:

Bosch Sicherheitssysteme GmbH
Robert-Bosch-Ring 5
85630 Grasbrunn
Germany

Bosch Security Systems, Inc.

12000 Portland Avenue South
Burnsville MN 55337
USA

www.electrovoice.com

© Bosch Security Systems 2017 | Data subject to change without notice.
2016.12 | 03 | F.01U.331.473